

LIFE-CYCLE INVENTORY OF FORMALDEHYDE-BASED RESINS USED IN WOOD COMPOSITES IN TERMS OF RESOURCES, EMISSIONS, ENERGY AND CARBON

*James B. Wilson**†

Professor Emeritus
Department of Wood Science and Engineering
Oregon State University
Corvallis, OR 97331-5751

(Received July 2009)

Abstract. Life-cycle inventory (LCI) data are needed to scientifically document the environmental performance of formaldehyde-based resins used in the manufacture of wood composite products. The resin data are needed by others to conduct LCI studies of wood composites when providing performance data for applications as governed by the many green building standards, purchasing guidelines, and energy and climate change-related policies. This study develops LCI data for urea–formaldehyde, melamine–urea–formaldehyde, phenol–formaldehyde, and phenol–resorcinol–formaldehyde resins as produced in the US for 2005. Data are given for both on-site (resin manufacture) and cradle-to-gate (from the resin upstream to in-ground resources), which include those resources to produce and deliver input chemicals, fuels, water, and electricity. The LCI data are given per 1.0 kg of neat (liquid) resin at their industry use solids content in terms of raw materials use and emissions to air, water, and land; data are also presented on embodied energy, carbon flow, store, and footprint.

Keywords: Environmental performance, formaldehyde-based resins, wood composites, life-cycle inventory, LCI, CORRIM, embodied energy, carbon footprint.

INTRODUCTION

The objective of this study was to develop the life-cycle inventory (LCI) data for most of the primary resin systems used in the manufacture of wood composites. Resins included in the study are urea–formaldehyde (UF), melamine–urea–formaldehyde (MUF), phenol–formaldehyde (PF), and phenol–resorcinol–formaldehyde (PRF)—all formaldehyde-based resins. An LCI consists of an accounting of all inputs and outputs of the manufacture of these resins; for this study, a system boundary was selected from their in-ground raw material resources (referred to as the cradle) through resin production (referred to as the product gate).

LCI cradle-to-gate data are invaluable when it comes to establishing a material's environmental performance, for conducting LCI studies of wood composites, as a benchmark for process improve-

ment, and addressing customer inquiries. For resins, the life-cycle issue is not the product itself, but more importantly as an input component in the LCI analysis of wood composites such as particleboard, medium-density fiberboard (MDF), oriented strandboard (OSB), laminated veneer lumber (LVL), I-joists, and laminated timbers (glulam)—all product databases developed by CORRIM in earlier studies (www.corrim.org). The resin acts as the enabler for these composites, providing strength, durability, performance, and enhanced wood resource use and efficiency.

The LCI data forms the foundation for the scientific assessment in terms of a variety of environmental performance measures. Furthermore, the data can be used to establish the performance of wood composites for many green type standards, guidelines, and policies. Specific environmental issues in which the data can be used are sustainability, global warming, climate change, carbon cap and trade, carbon taxes, carbon footprint, green purchasing, and green building.

* Corresponding author: jim.wilson@oregonstate.edu
† SWST member

The resins studied are all thermosets in that they are cured by chemical reaction to form a cross-linked polymer that cannot be remelted or reprocessed, although UF and some MUF resins may be reprocessed under certain conditions. The resins are usually applied as a liquid mix of resin, water, and possibly other ingredients to the wood during the production of wood composites. The amount of resin applied is dependent on the resin and wood composite type and can range 2 – 10% of the total composite dry weight. Catalyst, heat, and pressure may be required to cure UF, MUF, and PF resins, whereas hardeners are used to cure PRF resin either cold or hot. The hardeners for PRF resin are generally paraformaldehyde for glulam and oxazolidine for I-joists.

UF resins are used for interior use products such as particleboard, MDF, and hardwood plywood production. MUF resins are used to impart greater moisture and water resistance than UF resins and can be used for the production of the same products. The greater the content of melamine, the greater the moisture resistance with a low water resistance at 2% and high at 10% melamine based on liquid resin weight; for this study, the melamine content is 8%. PF resins are even more moisture-resistant and are used for exterior-use products such as softwood plywood, OSB, and LVL and are also used for hardboard. For the greatest moisture resistance, PRF resins are used to produce glulam and I-joists. Not included in this study is the LCI of isocyanate resin that can be used to produce OSB, particleboard, and MDF; it is used to impart faster cures for OSB manufacture and greater moisture and water resistance for particleboard and MDF. For additional background on these resin systems, see Marra (1992) and Pizzi (1994).

The urea-, melamine-, and phenolic-type resins were all developed in the early 20th century. Over the years, these products have evolved into highly engineered products designed to meet specific processing, emissions standards, and end-use requirements. The production of thermoset resins fall into the Standard Industrial

Classification Code 2821, plastic materials and resins (USCB 2007). The Source Classification Code for UF resin production is 30101832, for melamine-type resin production is 30101842, and phenolic resin production is 30101805 (USEPA 2007).

METHODOLOGY

An LCI was conducted for manufacturing of UF, MUF, PF, and PRF resins in the US for use in the wood composites industry; however, some Canadian production data may be included because the resin industry is closely tied between the two countries. Some resin production for nonwood uses may also be included in the data. This study covers the environmental impacts from the raw material resources such as natural gas and crude oil in the ground through to production of the resin in their liquid form as shipped to the customer. Individual resin manufacturing facilities were generally able to produce all four resins; however, because of market and production capacity, not all resins are produced at a given site. The manufacturing data for each resin were collected by survey of the industry; the data also included transportation of input chemicals to their production facilities. Data for the various facilities were very similar with the main difference because of emissions control approaches and the nuances of custom resin formulations. Industry weight-averaged data are given for what was deemed a typical resin formulation.

This study considers those impacts in the manufacture of resins, documenting all inputs of materials, fuels, and electricity and all outputs of product and emissions to air, water, and land. The boundary conditions are defined in terms of the on-site production facilities (referred to as gate-to-gate) and from resources in the ground to the production output of resin (referred to as cradle-to-gate). Primary data were collected by direct survey questionnaire of resin manufacturers; for a copy of the survey form, see Wilson (2009). Supplemental secondary data were obtained for impacts associated with the

manufacture, delivery, and consumption of electricity, fuels, and transportation (FAL 2004; PRé Consultants 2007; USDOE 2007). LCI data for input chemicals (Ecoinvent 2008) were adjusted to US energy and transportation values based on Franklin Associates database (FAL 2004) where possible.

This study follows International Organization for Standardization (ISO) 14040 and 14044 protocol (ISO 2006a, 2006b) and Consortium for Research on Renewable Industrial Materials (CORRIM) guidelines and format (CORRIM 2001). A report on the LCI of formaldehyde-based resins following protocol was completed and reviewed (Wilson 2009).

Manufacturing Process

The resin manufacturing processes for all four resins begin with the conversion of methanol by catalytic oxidation in a reactor vessel to produce an aqueous form of formaldehyde (Fig 1). The methanol is vaporized by warming, mixed with air, and then introduced into a reactor vessel containing a metal catalyst of either silver or

molybdenum–iron oxide in very small quantities. On exiting the reactor, the formaldehyde is cooled and then sent to the absorber to produce an aqueous solution. Heat is recovered during this process and used elsewhere within the process. The various formaldehyde resins are then produced in a batch reactor by reacting formaldehyde with urea, melamine, phenol, resorcinol, or some combination of these. The reaction process involves heating the mix and controlling the temperature, pH, molar ratio, and the rate of charging until the desired degree of polymerization is achieved. Formic acid, ammonium sulfate, and sodium hydroxide are used throughout the UF and MUF process primarily to make pH adjustments; however, for PF resin, sodium hydroxide is a major constituent that is used during the reaction to solvate and catalyze the PF polymer. The reaction is quenched and then cooled. If needed, water is stripped off to provide the desired percentage of resin solids. Most of the process water is recycled and used within the production process; eg any excess water generated in the production of UF resin can be used for PF resin. A significant amount of excess water and steam is used within these

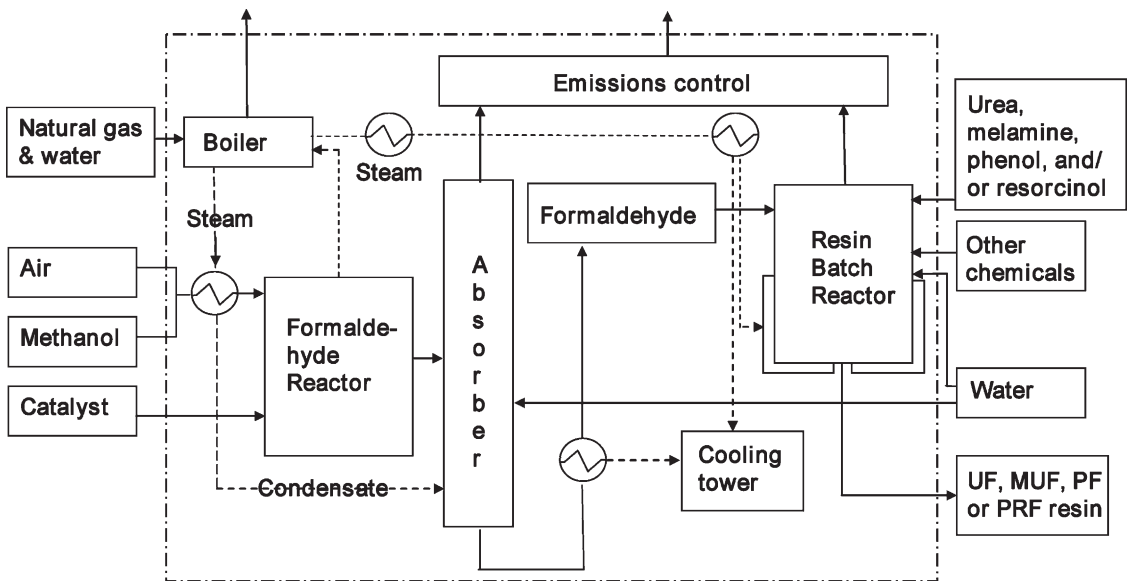

Figure 1. A generic process flowchart for the production of urea–formaldehyde (UF), melamine–urea–formaldehyde (MUF), phenol–formaldehyde (PF), and phenol–resorcinol–formaldehyde (PRF) resins.

integrated processes resulting in a very efficient use and reduced emissions. Very little waste is generated in resin production.

Production facilities generally used emissions control equipment—regenerative thermal oxidizers (RTOs), regenerative catalytic oxidizers (RCOs), and wet scrubbers—to reduce the type and percentage of some emissions. RTOs and RCOs required the additional use of electricity and natural gas for their operation.

It is noteworthy that essentially all production facilities started with methanol, and a very small amount (less than 1%) of formaldehyde was purchased for these operations; therefore, it was not included directly in the analysis. Instead, the LCI of the input formaldehyde was indirectly included by the modeling of resources to methanol and methanol to formaldehyde.

System Boundary Conditions

A black-box approach was selected for modeling the LCI of the resin production process. Whereas unit process approaches were used in earlier CORRIM studies of lumber and plywood production (Milota et al 2005; Wilson and Saki-

moto 2005), it was not needed in this case because unlike those processes that have a high percentage of coproduct generated at various steps throughout the process, resin production does not generate coproducts. In a black-box approach, only flows into and out of the box are considered. Both on-site and cradle-to-gate system boundaries were considered. Figure 2 gives the on-site system boundary that considers only on-site emissions to produce the resins and does not include those emissions for the production and delivery of input chemicals, fuels, and electricity. Only those inputs and outputs directly associated with the manufacturing process are considered—those emissions that occur because of on-site combustion of fuels whether for process heat or operating equipment. Figure 3 gives the cradle-to-gate system boundary for manufacturing resin from in-ground resources to resin that also includes the on-site inputs and emissions. All impacts are considered, including those for the manufacture and delivery of input chemicals, fuels, and electricity from raw resources in-ground through production of the resin ready for delivery. The production of various inputs to the resin process can involve many stages of processing.

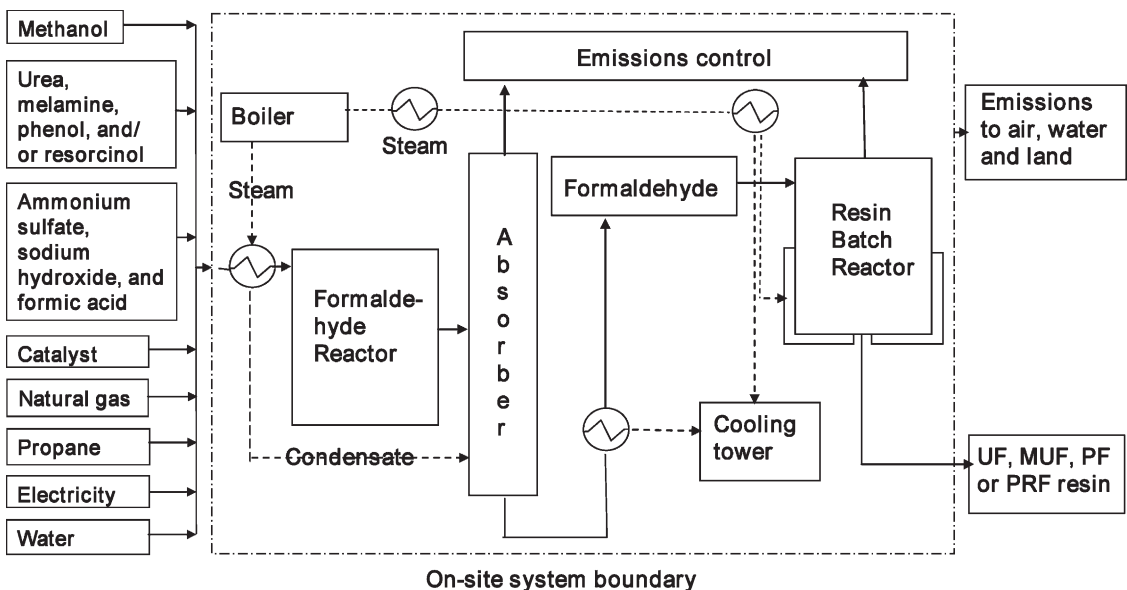

Figure 2. On-site (gate-to-gate) system boundary for resin production.

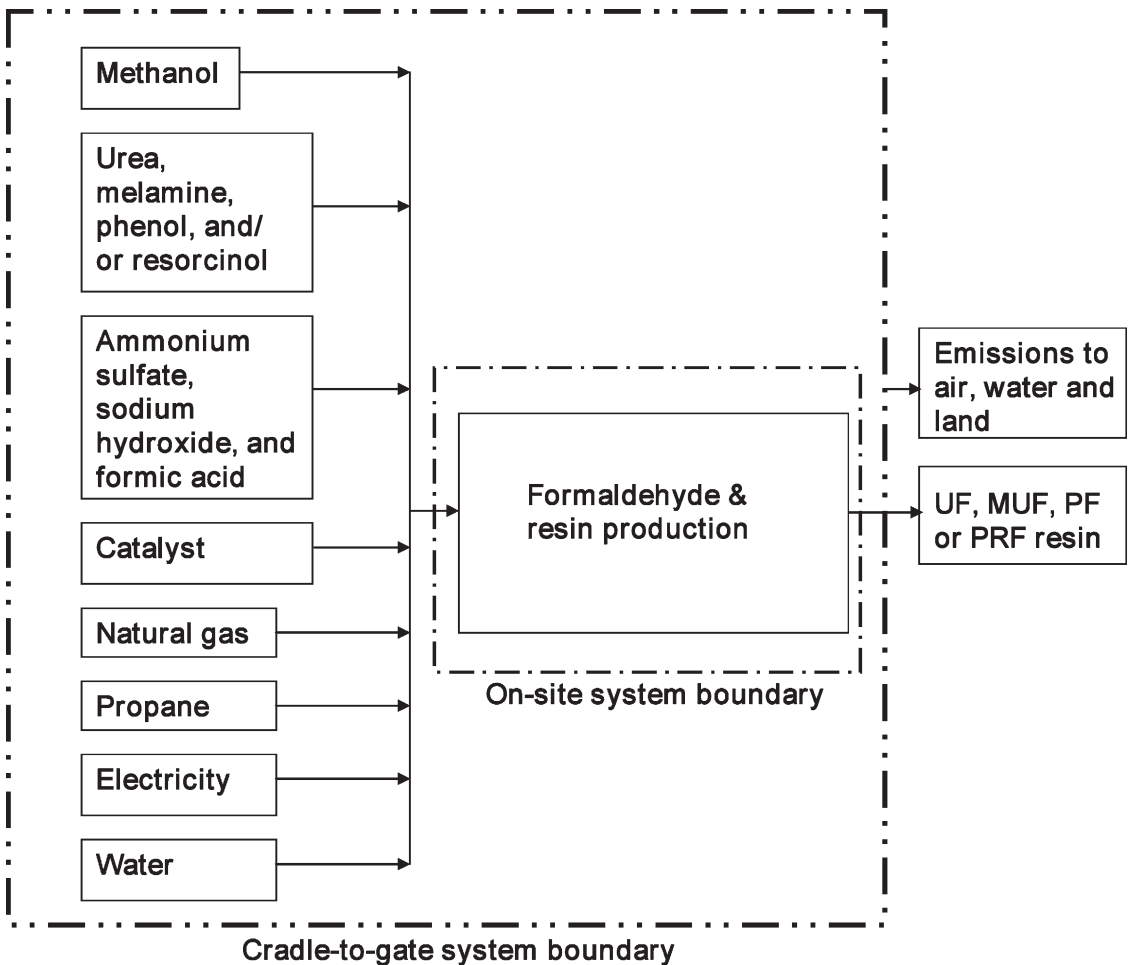

Figure 3. The cradle-to-gate system boundary for resin production.

The LCI of many of the input chemicals and electricity begins with natural gas or crude oil (both fossil fuel sources) as feedstock. The primary chemicals for the resins include methanol, urea, phenol, melamine, and resorcinol. Methanol, CH_3OH , the simplest of alcohols, is produced from natural gas feedstock. Urea, $(\text{NH}_2)_2\text{CO}$, is produced from ammonia that in turn is based on natural gas feedstock. Phenol, $\text{C}_6\text{H}_5\text{OH}$, starts with crude oil as a feedstock but goes through several production steps of oil to benzene, benzene to cumene, and cumene to phenol to complete the process. Melamine, $\text{C}_3\text{H}_6\text{N}_6$, is also based on natural gas as a feedstock because it is produced from urea. Resor-

cinol, $\text{C}_6\text{H}_4(\text{OH})_2$, is produced from crude oil feedstock. In addition to the use of natural gas and crude oil for feedstock to produce these chemicals, additional fossil fuels are used for transportation, process heat, and generation of electricity used in their manufacture.

Life-Cycle Inventory Modeling

An environmental impact analysis was done using SimaPro 7.1 software and included the Franklin Associates database (FAL) to provide impacts for fuels and electricity for the US (PRé Consultants 2007). The FAL database provides data on input materials and output product and

emissions for fuels and electricity for average industry technologies of the late 1990s. For materials not covered in the FAL database, the Ecoinvent v2.0 database (Ecoinvent 2008), a comprehensive database for Europe, was used to determine environmental impacts. The Ecoinvent database for input chemicals was adjusted to US fuels, electricity, and transportation data using FAL processes. Two system boundaries were modeled: 1) the on-site (gate-to-gate) for resin manufacture only; and 2) the cradle-to-gate to encompass all upstream impacts from the resin exiting the plant gate to include all material uses back to their in-ground resources.

Functional or Production Unit

The functional unit for all data is 1.0 kg of liquid resin at its stated nonvolatile solids content; eg the functional unit for UF resin is 1.0 kg at 65% solids. To determine the LCI data for a resin at 100% solids, divide their values by the decimal value of their stated-use solids percentage.

Assumptions

Specifics on all conditions and assumptions for this LCI study are given in a CORRIM report by Wilson (2009). The more significant assumptions are stated here:

- Mass-based allocation was used to assign environmental burdens to the resin based on the system boundary;
- To determine the energy content of fuels and feedstock, their higher heating value (HHV) was used; The energy content values were not used to calculate inputs to the SimaPro model; rather, the appropriate industry unit for fuel or feedstock of either kg, L, or m³, and for electricity kWh was used; and
- On-site emissions of CO₂ and CO were not reported in the survey questionnaires; these values were determined using Franklin Associates' database (FAL 2004) for the combustion of the various fuels based on their actual on-site use and representative industry technology.

Electricity Use

The source of fuel used to generate the electricity used in the manufacturing process is very important in determining the type and amount of environmental impact as a result of its use. The breakdown by fuel source to generate the electricity was based on the US average as stated by the Energy Information Administration for 2005 (EIA 2007). The dominant fuel source was coal at 49.6% followed by nuclear (19.3%) and natural gas (18.8%). The lesser contributing sources were hydroelectric (6.7%), petroleum (3.0%), and other renewables (2.2%); much smaller quantities are produced by other gases (0.4%) and other (0.3%). The generation of electricity by fuel source is used to assign environmental burdens in the SimaPro modeling of the various processes based on the FAL fuel processes for the US.

LIFE-CYCLE INVENTORY DATA

Survey Data Collection

A survey questionnaire was conducted of resin manufacturers to collect production data for 2005 in terms of input chemicals, electricity, fuel use, and outputs of resin and emissions (Wilson 2009). The resin manufacturing facilities were representative of US production practices. The UF resin data were for 16 plants and represented 70% of total US production, MUF was for 6 plants and represented 77% of production, PF was for 13 plants and represented 62% of production, and PRF was for 8 plants and represented 63% of production.

Resins with the largest annual production were UF (1,225,869,685 kg at 65% solids) and PF (779,063,416 kg at 47% solids), whereas smaller amounts were produced of MUF (86,588,648 kg at 60% solids) and PRF (15,513,018 kg at 60% solids) (Table 1). The resin production values were determined based on their use per unit of wood composites from earlier CORRIM reports (Kline 2005; Puettmann and Wilson 2005; Wilson and Dancer 2005a, 2005b; Wilson and Sakimoto 2005; Wilson 2010a, 2010b) and

Table 1. US annual production for 2005 of formaldehyde-based resins for the wood products industry.

Resin	Resin solids (%)	US resin production (kg liquid) ^a	Survey/US resin production (%)
Urea–formaldehyde (UF)	65	1,225,869,685	70
Melamine–urea–formaldehyde (MUF)	60	86,588,648	77
Phenol–formaldehyde (PF)	47	779,063,416	62
Phenol–resorcinol–formaldehyde (PRF)	60	15,513,018	63

^a Liquid resin at stated resin solids content.

industry 2005 production data for the various wood composites.

Survey Data Analysis

The survey data from the resin producers were analyzed for quality by assessing for outliers and determining the molar ratio of their major chemical components. Mass balances were also done, although these are chemical reactions so there can be differences. The data for each production facility were converted to a functional unit of 1.0 kg of neat (with water) resin at their specified solids content to make the comparison. Any outliers were resolved by contacting the producers. The molar ratio of formaldehyde to urea, melamine, phenol, and resorcinol of each resin was calculated and all were found to be within the expected range for the industry-specific application. The data for the plants were then weight-averaged based on the production of each plant and the total production for the surveyed group. Only the industry-wide, weight-averaged data are presented in this report. The data for all chemical inputs are given in kg on a dry or 100% solids basis per 1.0 kg of neat resin at their stated solids percentage.

The molar ratio (MR) of formaldehyde to the various major components was done assuming that it takes 1.2 kg of methanol to produce 1.0 kg of formaldehyde. The MR of each of the four resin types was found to be representative of industry use (Table 2). For UF resin, the MR of

Table 2. Molar ratio of the formaldehyde-based resins in this study.

Resin	Molar ratio
Urea–formaldehyde (UF)	F:U 1.09
Melamine–urea–formaldehyde (MUF)	F:(M + U) 1.16
Phenol–formaldehyde (PF)	F:P 2.23
Phenol–resorcinol–formaldehyde (PRF)	F:(P + R) 0.61

F, formaldehyde; U, urea; M, melamine; P, phenol; R, resorcinol.

formaldehyde to urea was 1.09, which is the expected value for use in the particleboard and MDF industries. For MUF resin, the MR of formaldehyde to urea plus melamine was 1.16 (with a possible industry range of 1.15 – 1.30), which is an expected value for resin use in the particleboard and MDF industries. For the PF resin, the MR of formaldehyde to phenol was 2.23 (with a possible industry range of 2.00 – 2.25), which is typical for use in the softwood plywood and laminated veneer lumber industries. For PRF resin, the MR of 0.61 (typically below 1.0 in the industry) of formaldehyde to phenol plus resorcinol was as expected for use in the glue-laminated beam and I-joist industries. The value of the MR affects both the performance of the resin and the properties of the composite panel made with the resin. The value of the MR also affects the quantity of formaldehyde emissions from the UF and MUF bonded panels with the lower of the ratio, the lower the emissions. The industry continues to make significant strides in lowering the MR to meet regulatory standards but maintaining favorable resin and panel properties.

LIFE-CYCLE INVENTORY INPUTS AND OUTPUTS

Transportation

The delivery of chemicals to the resin plants is by both truck and rail. Table 3 gives the one-way delivery distances. Usually the truck deliveries have no back haul of other materials. The delivery weights of the input chemicals, which includes their water component to provide the desired solids percentage, are used to determine the t·km (the mass [t for tonne] times distance traveled [km]) values used as input to the Sima-

Pro software by accessing the FAL database to obtain US typical impacts for truck and rail transportation. Other chemicals are used in the resin production process, but their quantity and contribution to environmental impacts were so insignificant that they were not included in either the survey data or the transportation calculations.

On-Site Resources Use

Those materials considered in the LCI analysis of the various resins produced are listed in Table 4. Also provided are their solids content as used in the resin plant; these weights were used to determine transportation and in-plant use impacts. Other chemicals used were of minor contribution totaling much less than 1%

weight of resin and were not included in the analysis. The silver or molybdenum-iron oxide catalyst used to convert methanol to formaldehyde was not included in the analysis because it is a very small contributor to the analysis and the manufacturers considered this information proprietary.

The inputs to produce 1.0 kg of neat resin at their stated nonvolatile solids content are given in Table 5. The inputs consist of methanol to make the formaldehyde and the addition of the primary chemicals of urea, melamine, phenol, and resorcinol along with acids, caustics, and a catalyst. A significant portion of the processing water is recycled back into the resin. Electricity is used in such processing as fans and pumps and for operating emissions control equipment, whereas natural gas is used for boiler fuel and

Table 3. *One-way delivery distance for input chemicals to resin plants.*

Chemical	Delivery mode	UF resin		MUF resin		PF resin		PRF resin	
		Delivery mode (%)	One-way distance (km)	Delivery mode (%)	One-way distance (km)	Delivery mode (%)	One-way distance (km)	Delivery mode (%)	One-way distance (km)
Urea	Truck	12	314	14	123				
Urea	Rail	88	958	86	792				
Melamine	Truck			100	1989				
Phenol	Truck					36	230	12	84
Phenol	Rail					64	1615	88	2507
Resorcinol	Truck							100	4344
Methanol	Truck	15	242	16	260			12	421
Methanol	Rail	85	1986	84	1990	100	2025	88	2026
Formic acid	Truck	100	347	100	347				
Ammonium sulfate	Truck	100	347	100	347				
Sodium hydroxide	Truck	100	347	100	347	100	297	100	143
Ethanol	Truck							100	143

UF, urea-formaldehyde; MUF, melamine-urea-formaldehyde; PF, phenol-formaldehyde; PRF, phenol-resorcinol-formaldehyde.

Table 4. *Input chemicals used to produce the formaldehyde-based resins.*

Resin type UF (65%) ^a Input materials	Resin type MUF (60%) Input materials	Resin type PF (47%) Input materials	Resin type PRF (60%) Input materials
Urea (100%) ^b	Melamine (100%)	Phenol (100%)	Phenol (100%)
Methanol (100%)	Urea (100%)	Methanol (100%)	Resorcinol (100%)
Formic acid (10%)	Methanol (100%)	Sodium hydroxide (50%)	Methanol (100%)
Ammonium sulfate (20%)	Formic acid (10%)	Water	Ethanol (100%)
Sodium hydroxide (50%)	Ammonium sulfate (20%)		Sodium hydroxide (50%)
Water	Sodium hydroxide (50%)		Water
	Water		

^a Solids content of liquid resin out of the plant.

^b Solids content or solution strength of chemicals into the plant.

emission control equipment such as RTOs and RCOs and propane is used for fuel in forklifts.

Table 6 gives the energy use on-site based on the fuel and electricity use values in Table 5 for manufacturing the various resins. Natural gas is the primary fuel in resin manufacturing, it is used for generating steam that is used to heat input chemicals and reactors, and is used for combusting emissions. Natural gas provides about 75% of the energy and electricity about 25%. Propane is an insignificant contributor to energy use. The total on-site energy use of electricity and fuels based on their HHVs ranged from 0.394 MJ/kg for UF to 1.58 MJ/kg for PRF resins.

On-Site Resin and Emissions Output

LCI outputs for the production of 1.0 kg of resin include emissions to air, water, and land (Table 7). Emissions are generated because of combustion of natural gas and propane and the chemical reactions in the reactors. For fuel combustion, only CO₂ and CO are given; both were calculated using the SimaPro software, the actual natural gas and propane used, and the FAL database for US fuels. The FAL database provides data on emissions for the combustion of various fuels for average industry technologies of the late 1990s. All other emissions were collected by survey; they include emissions to air of volatile organic compounds (VOCs), particulate, hazardous air pollutant emissions of formaldehyde and

Table 5. Inputs for the production of 1.0 kg of neat resin at their stated solids.

	Unit	Unit/kg UF 65% solids	Unit/kg MUF 60% solids	Unit/kg PF 47% solids	Unit/kg PRF 60% solids
Chemicals^a					
Urea	kg	4.73E-01	3.97E-01		
Melamine	kg		8.08E-02		
Phenol	kg			2.44E-01	2.77E-01
Resorcinol	kg				1.90E-01
Methanol	kg	3.09E-01	3.04E-01	2.09E-01	1.03E-01
Formic acid	kg	4.74E-05	5.09E-05		
Ammonium sulfate	kg	3.16E-05	2.94E-05		
Sodium hydroxide	kg	2.22E-04	2.09E-04	6.10E-02	3.72E-03
Ethanol	kg				7.44E-03
Water					
Water for producing resin	kg	3.33E-02	1.27E-01	2.97E-01	2.20E-01
Water use, cooling tower	kg	4.57E-01	5.79E-01	1.56E-02	2.91E-01
Water other, boiler makeup	kg	9.47E-03	8.50E-02	3.72E-02	1.45E-01
Fuel use					
Electricity, process	kWh	1.77E-02	2.09E-02	2.20E-02	8.30E-02
Electricity, emissions control	kWh	1.36E-02	1.42E-02	1.36E-02	1.59E-02
Natural gas	m ³	7.34E-03	1.35E-02	8.21E-03	3.18E-02
Propane	L	9.35E-06	1.55E-05	2.93E-06	2.50E-05

^a All chemicals weights given at 100% nonvolatile solids, 100% solution strength or dry weight.

UF, urea-formaldehyde; MUF, melamine-urea-formaldehyde; PF, phenol-formaldehyde; PRF, phenol-resorcinol-formaldehyde.

Table 6. On-site energy for electricity and fuel use for the manufacture of 1.0 kg of neat resin.

Energy use ^a	UF resin		MUF resin		PF resin		PRF resin	
	MJ/kg	%	MJ/kg	%	MJ/kg	%	MJ/kg	%
Electricity, process	6.38E-02	16.2	7.53E-02	11.7	7.94E-02	17.9	2.99E-01	19.0
Electricity, emissions control	4.91E-02	12.5	5.11E-02	7.9	4.91E-02	11.1	5.71E-02	3.6
Natural gas	2.81E-01	71.4	5.17E-01	80.3	3.15E-01	71.0	1.22E+00	77.4
Propane	3.56E-07	0.0	5.89E-07	0.0	1.12E-07	0.0	9.51E-07	0.0
Total energy	3.94E-01	100	6.43E-01	100	4.43E-01	100	1.58E+00	100

^a Electricity kWh = 3.6 MJ; higher heating values (HHV) for natural gas 54.4 MJ/kg and propane 54.0 MJ/kg.

UF, urea-formaldehyde; MUF, melamine-urea-formaldehyde; PF, phenol-formaldehyde; PRF, phenol-resorcinol-formaldehyde.

Table 7. On-site reported outputs for the production of 1.0 kg of the various formaldehyde-based resins at their stated nonvolatile solids.

	UF resin (kg/kg resin)	MUF resin (kg/kg resin)	PF resin (kg/kg resin)	PRF resin (kg/kg resin)
Production output				
Resin, neat ^a	1.00	1.00	1.00	1.00
Emissions to air				
CO ₂ , ^b fossil (GHG) ^c	1.56E-02	2.55E-02	1.76E-02	6.85E-02
CO ^b	3.39E-05	1.30E-05	3.81E-05	1.49E-04
VOC	5.14E-05	4.94E-05	2.89E-05	3.38E-05
Particulate	2.31E-06	1.65E-06	2.31E-06	3.01E-06
Formaldehyde (HAP) ^c	7.79E-06	7.85E-06	6.69E-06	8.80E-06
Methanol (HAP)	6.08E-06	5.49E-06	3.20E-06	5.20E-06
Dimethyl ether	2.18E-05	2.26E-05	4.73E-06	
Phenol (HAP)			2.04E-06	4.16E-06
Emissions to water				
BOD	6.16E-04	6.62E-04		2.81E-03
TSS	3.66E-04	3.94E-04		1.67E-04
Solids	2.23E-04	2.39E-04		
Ammonia nitrogen	1.21E-04	1.30E-04		
Formaldehyde	7.29E-05	7.84E-05		3.32E-04
Phenol				1.14E-04
Emissions to land				
Solids	2.23E-04	5.09E-05	2.00E-04	1.65E-04

^a Resins are liquid weight at stated solids of UF 65%, MUF 60%, PF 47%, and PRF 60%.

^b CO₂ and CO were calculated using SimaPro and input of natural gas and propane fuel use in plant.

^c GHG, greenhouse gas; HAP, hazardous air pollutant.

UF, urea-formaldehyde; MUF, melamine-urea-formaldehyde; PF, phenol-formaldehyde; PRF, phenol-resorcinol-formaldehyde; VOC, volatile organic compound; BOD, biological chemical demand; TSS, total suspended solids.

methanol, and dimethyl ether and phenol from the absorber and reactor. The dimethyl ether emissions are a byproduct from the molybdenum-iron oxide process. Emissions to water include biological chemical demand, total suspended solids, solids, ammonia nitrogen (NH₃N), formaldehyde, and phenol.

Emissions data that are not present for some resins can be accounted for by the chemistry of the specific process, eg dimethyl ether (DME) is not present for PRF resin production because most of the plants used silver catalyst that does not produce measurable DME emissions and there are no emissions to water for PF resin because all water from the process is used within it to make the resin.

Cradle-to-Gate Resource Use and Emissions

The LCI for the production of the resins covers their cycle from in-ground resources through the production and delivery of input chemicals

and fuels through manufacture of resins as shipped to the customer. It examines the use of all resources, fuels, and electricity and all emissions to air, water, and land; it also includes feedstock of natural gas and crude oil used to produce input chemicals. Table 8 gives the raw materials and energy input resources, and Tables 9 and 10 give the output emissions to air, water, and land for the cradle-to-gate inventory. The in-ground raw materials include coal, natural gas, limestone, crude oil, uranium, water use, and others. Materials of quantities smaller than 1.0E-06 kg/kg of resin are not included in the listing. Because life-cycle studies involve tracing resource use back to its in-ground resources, some materials or substances can involve many steps of backtracking to their source that results in the use of a large number of substances, many of insignificant quantity. For this study, a filter was used to remove insignificant substances from the listing. The filter varied depending on whether the emission was to air, water, or land. The exception was for substances

Table 8. *Life-cycle inventory input of allocated raw materials cradle-to-gate for the production of 1.0 kg of liquid resin at their stated solids.*

Raw material	UF resin ^a (kg/kg resin)	MUF resin ^a (kg/kg resin)	PF resin ^a (kg/kg resin)	PRF resin ^a (kg/kg resin)
Aluminium, 24% in bauxite, 11% in crude ore, in ground	4.69E-05	4.62E-05	3.20E-05	1.65E-05
Anhydrite, in ground			2.64E-06	3.02E-06
Barite, 15% in crude ore, in ground	1.33E-06	1.27E-06	2.74E-04	1.81E-05
Calcite, in ground	9.66E-04	1.04E-03	5.27E-03	1.19E-03
Carbon dioxide, in air	2.74E-05	2.89E-05	1.64E-04	5.21E-05
Clay, bentonite, in ground			2.78E-05	3.16E-05
Clay, unspecified, in ground	2.02E-04	2.18E-04	3.92E-04	3.00E-04
Coal, 26.4 MJ/kg, in ground	6.79E-02	8.00E-02	1.28E-01	1.05E-01
Coal, brown, in ground	1.88E-04	1.97E-04	1.30E-03	1.71E-04
Coal, hard, unspecified, in ground	1.53E-04	1.60E-04	1.94E-02	2.10E-02
Copper, 0.99% in sulfide, . . . in crude ore, in ground	1.04E-06	1.02E-06	1.53E-06	1.29E-06
Copper, 1.18% in sulfide, . . . in crude ore, in ground	5.79E-06	5.67E-06	3.90E-06	1.92E-06
Copper, 1.42% in sulfide, . . . in crude ore, in ground	1.53E-06	1.51E-06	1.03E-06	
Copper, 2.19% in sulfide, . . . in crude ore, in ground	7.61E-06	7.46E-06	5.13E-06	2.53E-06
Dolomite, in ground			1.39E-06	1.58E-06
Fluorspar, 92%, in ground	1.62E-06	1.72E-06		
Gas, mine, off-gas, process, coal mining/m ³	1.15E-06	1.21E-06	9.78E-06	3.12E-06
Gas, natural, 46.8 MJ/kg, in ground	3.84E-01	4.07E-01	2.28E-01	1.67E-01
Gas, natural, in ground	7.83E-05	8.23E-05	1.49E-01	1.72E-01
Gravel, in ground	7.72E-03	8.34E-03	2.55E-04	1.32E-04
Iron, 46% in ore, 25% in crude ore, in ground	8.35E-06	8.21E-06	1.86E-04	2.10E-04
Limestone, in ground	3.92E-03	4.61E-03	7.35E-03	6.08E-03
Molybdenum, 0.022% in sulfide, . . . in crude ore, in ground	3.00E-06	2.94E-06	2.02E-06	2.01E-06
Molybdenum, 0.11% in sulfide, . . . in crude ore, in ground	6.05E-06	5.94E-06	4.08E-06	
Nickel, 1.13% in sulfide, . . . in crude ore, in ground	2.63E-04	2.84E-04	5.27E-06	2.60E-06
Nickel, 1.98% in silicates, 1.04% in crude ore, in ground	1.30E-06	1.27E-06	1.68E-06	1.33E-06
Oil, crude, 42 MJ/kg, in ground	1.42E-01	1.57E-01	1.89E-02	3.51E-02
Oil, crude, in ground	3.06E-04	3.25E-04	3.11E-01	3.57E-01
Olivine, in ground				1.02E-06
Peat, in ground			6.05E-05	7.01E-05
Phosphorus, 18% in apatite, 4% in crude ore, in ground				1.47E-06
Resorcinol				1.90E-01
Sand, unspecified, in ground			3.21E-05	3.67E-05
Shale, in ground			7.48E-06	8.56E-06
Sodium chloride, in ground	4.76E-04	4.53E-04	1.04E-01	7.04E-03
Sulfur, in ground			2.16E-05	2.49E-05
Uranium, 2291 GJ/kg, in ground	2.90E-07	3.41E-07	5.46E-07	4.52E-07
Uranium, in ground	8.45E-09	8.89E-09	1.20E-06	1.32E-06
Water, cooling, unspecified natural origin/kg			1.60E-02	
Water, cooling, unspecified natural origin/m ³	2.76E+00	4.66E+00	4.37E+01	4.20E+01
Water, lake	9.40E-05	1.00E-04	1.56E-04	1.19E-03
Water, process, drinking	2.93E-01	2.87E-01	1.97E-01	9.72E-02
Water, process, unspecified natural origin/kg	4.20E-01	6.88E-01	2.97E-01	
Water, process, well, in ground	8.00E-02	1.03E-01	3.70E-02	2.00E-01
Water, river	1.29E-02	1.35E-02	1.08E-01	1.02E-01
Water, salt, ocean	6.62E-04	6.97E-04	1.54E-01	1.73E-01
Water, salt, sole	2.23E-04	2.37E-04	2.41E-04	1.81E-04
Water, unspecified natural origin/kg				4.60E-01
Water, unspecified natural origin/m ³	6.52E-01	1.19E+00	4.79E-01	8.23E+00
Water, well, in ground	3.45E-02	3.73E-02	7.20E-03	3.89E-03
Wood and wood waste, 9.5 MJ/kg	2.83E-04	3.10E-04	1.75E-04	1.50E-04
Wood, hard, standing	2.06E-06	2.16E-06	1.21E-05	1.77E-06

(continued)

Table 8. *Continued.*

Raw material	UF resin ^a (kg/kg resin)	MUF resin ^a (kg/kg resin)	PF resin ^a (kg/kg resin)	PRF resin ^a (kg/kg resin)
Wood, soft, standing	1.15E-05	1.21E-05	6.88E-05	2.65E-05
Zinc, 9.0% in sulfide, An 5.3%, Pb, Ag, Cd, In, in ground	1.11E-05	1.09E-05	7.48E-06	3.69E-06
	(MJ/kg resin)	(MJ/kg resin)	(MJ/kg resin)	(MJ/kg resin)
Electricity from other gases	3.55E-03	4.22E-03	7.18E-03	5.92E-03
Electricity from other renewables	2.04E-02	2.43E-02	4.13E-02	3.41E-02
Electricity from hydro power	6.04E-02	7.18E-02	1.22E-01	1.01E-01
Energy, gross calorific value, in biomass	2.81E-04	2.97E-04	3.98E-02	4.44E-02
Energy, kinetic (in wind), converted	7.61E-05	8.00E-05	5.34E-04	7.10E-05
Energy, potential (in hydropower reservoir), converted	7.86E-03	8.46E-03	3.32E-02	3.41E-02
Energy, solar, converted	1.12E-06	1.18E-06	7.77E-06	1.22E-06

^a Resins are liquid weight at stated solids of UF 65%, MUF 60%, PF 47%, and PRF 60%.

UF, urea-formaldehyde; MUF, melamine-urea-formaldehyde; PF, phenol-formaldehyde; PRF, phenol-resorcinol-formaldehyde.

Table 9. *Life-cycle inventory output of emissions to air cradle-to-gate for production of 1.0 kg of liquid resin at their stated solids.*

Emissions to air	UF resin ^a (kg/kg resin)	MUF resin ^a (kg/kg resin)	PF resin ^a (kg/kg resin)	PRF resin ^a (kg/kg resin)
Acetic acid	4.84E-06	5.25E-06		
Aldehydes, unspecified	1.93E-05	2.36E-05	9.77E-06	2.36E-05
Aluminum	4.56E-06	4.89E-06		
Ammonia	1.64E-03	1.91E-03	4.64E-06	1.66E-06
Benzene	5.43E-06	5.89E-06	4.52E-04	5.13E-04
Butane	9.50E-06	1.03E-05		
Carbon dioxide, biogenic	4.53E-04	4.88E-04	1.89E-03	1.84E-03
Carbon dioxide, fossil	1.52E+00	1.68E+00	1.16E+00	1.23E+00
Carbon disulfide	1.92E-06	2.05E-06		
Carbon monoxide	2.03E-03	2.27E-03	1.27E-03	1.52E-03
Carbon monoxide, biogenic			1.65E-06	1.79E-06
Carbon monoxide, fossil	1.40E-03	1.52E-03	7.36E-04	8.34E-04
Chlorine			1.89E-06	
Cumene			6.54E-04	7.42E-04
Dimethyl ether	2.18E-05	2.26E-05	4.73E-06	
Dinitrogen monoxide	1.04E-05	1.14E-05	2.86E-06	2.24E-06
Ethanol	1.41E-06	1.52E-06		
Ethene			1.82E-06	1.08E-05
Formaldehyde	1.13E-05	1.17E-05	6.73E-06	8.83E-06
Hydrocarbons, aliphatic, alkanes, unspecified	2.82E-06	3.06E-06	1.29E-06	1.46E-06
Hydrocarbons, aromatic			8.38E-06	9.69E-06
Hydrogen			4.09E-05	1.24E-05
Hydrogen chloride	1.91E-05	2.18E-05	3.29E-05	2.98E-05
Hydrogen fluoride	2.38E-06	2.74E-06	3.60E-06	3.05E-06
Isocyanic acid		3.49E-04		
Lead	3.00E-09	3.23E-07	2.87E-08	2.08E-08
Mercury	6.77E-09	7.80E-09	1.21E-08	8.55E-09
Methane	2.82E-03	3.03E-03	2.09E-03	1.58E-03
Methane, biogenic	2.14E-06	2.61E-06	1.03E-05	9.94E-06
Methane, fossil	6.81E-04	7.07E-04	4.50E-03	5.02E-03
Methanol	1.73E-04	1.69E-04	1.14E-04	5.98E-05
Methyl formate	1.25E-06	1.34E-06		
Nickel	3.24E-06	3.51E-06	1.41E-06	1.56E-06
Nitrogen oxides	3.40E-03	3.84E-03	3.37E-03	3.70E-03
NM VOC (nonmethane VOC), unspecified origin	4.48E-03	4.81E-03	3.05E-03	2.80E-03

(continued)

Table 9. *Continued.*

Emissions to air	UF resin ^a (kg/kg resin)	MUF resin ^a (kg/kg resin)	PF resin ^a (kg/kg resin)	PRF resin ^a (kg/kg resin)
Organic substances, unspecified	6.40E-05	1.28E-04	6.00E-05	3.24E-04
Particulates	2.31E-06	1.65E-06	2.31E-06	3.01E-06
Particulates, <10 μm	1.54E-04	1.82E-04	1.52E-04	2.19E-04
Particulates, <2.5 μm	5.51E-04	5.97E-04	4.16E-05	4.63E-05
Particulates, >10 μm	4.28E-04	4.64E-04	5.58E-05	6.00E-05
Particulates, >2.5 μm and <10 μm	2.17E-04	2.35E-04	7.00E-05	7.93E-05
Particulates, unspecified	2.11E-04	2.45E-04	3.33E-04	2.78E-04
Pentane	1.63E-05	1.76E-05		
Phenol			2.05E-06	4.17E-06
Propane	2.87E-06	3.11E-06		2.75E-04
Propene			2.42E-04	
Sodium	3.52E-06	3.81E-06		
Sulfur dioxide	2.99E-04	3.23E-04	1.26E-03	1.42E-03
Sulfur oxides	1.44E-02	1.54E-02	9.80E-03	7.49E-03
Toluene	2.85E-06	3.09E-06		
Vanadium	1.22E-05	1.32E-05		
VOC (volatile organic compounds)	5.14E-05	4.73E-05	2.89E-05	3.38E-05
Water	6.53E-06	7.00E-06		
Heat, waste	(MJ/kg resin)	(MJ/kg resin)	(MJ/kg resin)	(MJ/kg resin)
	2.21E+01	2.39E+01	9.22E+00	9.08E+00
Nobel gases, radioactive, unspecified	(Bq/kg resin)	(Bq/kg resin)	(Bq/kg resin)	(Bq/kg resin)
	1.42E+02	1.49E+02	9.40E+02	1.44E+02
Radioactive species, unspecified	3.24E+03	3.81E+03	6.03E+03	5.29E+03
Radon-222	2.71E+02	2.86E+02	1.77E+03	3.04E+02

^a Resins are liquid weight at stated solids of UF 65%, MUF 60%, PF 47%, and PRF 60%.

UF, urea-formaldehyde; MUF, melamine-urea-formaldehyde; PF, phenol-formaldehyde; PRF, phenol-resorcinol-formaldehyde.

that are highly toxic such as uranium, lead, and mercury (generally from the production of electricity) where values less than the cutoff value were shown.

Some sources of energy or fuels cannot be traced back to their original resource in the ground. Such energies include energy from hydroelectric power, electricity from other gases, and electricity from renewables, which are not defined in terms of identifiable fuels and are given in MJ/kg of resin.

Emissions for the cradle-to-gate scenario are listed in Tables 9 and 10. The emissions to air and water used a cutoff value of 1.0E-06 kg/kg resin, and radiation-type emissions had a cutoff of 1.0E+00 Bq/kg resin. Emissions to land used a cutoff of 1.0E-06 kg/kg resin. Some emissions because of their toxicity, although in quantities below the cutoff value, are also shown. Raw materials and emissions for a cradle-to-gate inventory are far greater in general than those resources and emissions that occur at the resin

production site; this is true for all processes. The difference between on-site and cradle-to-gate resource use can be found by comparing Table 5 with Table 8 and emissions differences by comparing Table 7 with Tables 9 and 10.

Cradle-to-Gate Embodied Energy

The embodied energy to produce the various resins can be given in several formats. For this study, it is useful to examine the energy breakdown both in terms of its source of fuel and feedstock in the ground and its contribution by the various input substances. The natural gas and crude oil feedstock to produce chemicals was considered in terms of their higher heating values along with the energy of the various fuels.

Table 11 gives the cumulative energy equivalent from cradle-to-gate for the production of resins in terms of their fuel and feedstock source in the ground. For example, producing 1.0 kg of UF resin takes 29.35 MJ of embodied energy based

Table 10. *Life-cycle inventory output of allocated emissions to water and land cradle-to-gate for production of 1.0 kg of liquid resin at their stated solids.*

Emissions to water	UF resin ^a (kg/kg resin)	MUF resin ^a (kg/kg resin)	PF resin ^a (kg/kg resin)	PRF resin ^a (kg/kg resin)
Aluminum	3.54E-06	3.67E-06	6.67E-05	6.17E-05
Ammonia, as N	1.21E-04	1.30E-04		
Ammonium, ion	1.71E-04	1.86E-04	5.43E-06	1.42E-06
Antimony			1.66E-06	1.90E-06
Benzene			1.07E-03	1.22E-03
BOD5 (biological oxygen demand)	7.03E-04	7.51E-04	1.00E-02	1.42E-02
Boron	6.95E-06	8.14E-06	1.26E-05	1.05E-05
Bromate			1.59E-05	1.05E-06
Bromine			1.46E-06	1.66E-06
Calcium, ion	3.20E-05	3.42E-05	2.96E-04	7.56E-05
Carbonate			3.32E-05	3.78E-05
Chlorate			1.22E-04	8.06E-06
Chloride	1.01E-03	1.06E-03	1.88E-03	5.87E-04
Chromium				1.05E-06
COD (chemical oxygen demand)	3.87E-04	4.03E-04	1.04E-02	1.17E-02
Copper, ion			1.35E-06	1.52E-06
Cumene			1.57E-03	1.78E-03
DOC (dissolved organic carbon)	8.91E-05	8.88E-05	3.05E-03	3.42E-03
Fluoride			2.80E-06	3.10E-06
Formaldehyde	1.04E-04	1.09E-04	2.09E-05	3.42E-04
Hydrocarbons, unspecified			5.72E-06	6.57E-06
Iron	9.30E-06	1.10E-05	1.74E-05	1.44E-05
Iron, ion	4.89E-06	5.25E-06	1.45E-05	9.47E-06
Lead	6.08E-08	6.48E-08	3.47E-07	3.69E-07
Magnesium			3.25E-05	7.62E-06
Manganese	5.34E-06	6.29E-06	1.02E-05	8.48E-06
Mercury	2.82E-10	2.77E-10	7.23E-09	7.84E-09
Metallic ions, unspecified	3.32E-06	3.69E-06		
Methanol	9.30E-06	9.12E-06	6.27E-06	3.09E-06
Nickel, ion	1.40E-06	1.52E-06		
Nitrate			3.16E-05	3.76E-06
Nitrogen	5.78E-05	6.27E-05	1.24E-06	
Nitrogen, organic bound		1.01E-06		
Oils, unspecified	3.64E-04	3.86E-04	2.23E-04	1.68E-04
Organic substances, unspecified	5.94E-05	6.31E-05	3.69E-05	2.72E-05
Phenol	3.11E-06	3.06E-06	2.34E-06	1.15E-04
Phosphate		1.12E-06	1.38E-05	1.96E-05
Phosphorus	3.10E-06	3.04E-06	2.18E-06	1.06E-06
Potassium, ion			8.47E-05	9.38E-05
Propene			5.79E-04	6.57E-04
Silicon	3.41E-04	3.68E-04	3.18E-04	2.57E-04
Sodium, ion	2.89E-05	2.90E-05	1.22E-04	1.27E-04
Solids, inorganic	2.24E-04	2.40E-04	1.35E-04	9.25E-06
Solved solids	2.04E-02	2.16E-02	1.21E-02	8.86E-03
Sulfate	8.49E-04	9.05E-04	1.39E-03	7.56E-04
Sulfuric acid	1.73E-06	2.03E-06	3.07E-06	2.54E-06
Suspended solids, inorganic		3.94E-04		1.67E-04
Suspended solids, unspecified	6.63E-04	3.35E-04	3.36E-04	3.01E-04
TOC (total organic carbon)		8.88E-05	3.06E-03	3.43E-03
Zinc, ion			1.89E-06	2.05E-06
	(MJ/kg resin)	(MJ/kg resin)	(MJ/kg resin)	(MJ/kg resin)
Heat, waste	1.26E-01	1.24E-01	9.07E-02	4.37E-02

(continued)

Table 10. *Continued.*

Emissions to water	UF resin ^a (kg/kg resin)	MUF resin ^a (kg/kg resin)	PF resin ^a (kg/kg resin)	PRF resin ^a (kg/kg resin)
	(Bq/kg resin)	(Bq/kg resin)	(Bq/kg resin)	(Bq/kg resin)
Hydrogen-3, tritium	6.33E+00	6.66E+00	4.19E+01	6.44E+00
Emissions to land	(kg/kg resin)	(kg/kg resin)	(kg/kg resin)	(kg/kg resin)
Oils, unspecified	1.24E-06	1.32E-06		
Solids	2.23E-04	5.09E-05	2.00E-04	1.65E-04
Waste, solid	6.75E-02	7.51E-02	7.87E-02	6.30E-02

^a Resins are liquid weight at stated solids of UF 65%, MUF 60%, PF 47%, and PRF 60%.

UF, urea-formaldehyde; MUF, melamine-urea-formaldehyde; PF, phenol-formaldehyde; PRF, phenol-resorcinol-formaldehyde.

Table 11. *A breakdown by fuel resource in terms of their energy content to produce resins cradle-to-gate.*

Fuel source	UF resin ^a		MUF resin ^a		PF resin ^a		PRF resin ^a	
	MJ/kg resin ^b	%	MJ/kg resin ^b	%	MJ/kg resin ^b	%	MJ/kg resin ^b	%
Coal in ground	1.79E+00	6.1	2.11E+00	6.7	3.88E+00	9.6	3.32E+00	8.2
Crude oil in ground	6.47E+00	22.0	7.18E+00	22.7	1.50E+01	37.2	1.78E+01	44.1
Natural gas in ground	2.09E+01	71.1	2.21E+01	69.9	2.05E+01	50.9	1.84E+01	45.5
Uranium in ground	1.17E-01	0.4	1.33E-01	0.4	6.66E-01	1.6	6.76E-01	1.7
Wood fuel	1.48E-03	0.0	3.23E-03	0.0	1.83E-03	0.0	1.56E-03	0.0
Energy, from hydro power	6.04E-02	0.2	7.18E-02	0.2	1.22E-01	0.3	1.01E-01	0.2
Energy, potential (hydropower res.)	7.86E-03	0.0	8.46E-03	0.0	3.32E-02	0.1	3.41E-02	0.1
Electricity from other gases	3.55E-03	0.0	4.22E-03	0.0	7.18E-03	0.0	5.92E-03	0.0
Electricity from other renewables	2.04E-02	0.1	2.43E-02	0.1	4.13E-02	0.1	3.41E-02	0.1
Energy, gross calorific value, in biomass					3.98E-02	0.1	4.44E-02	0.1
Total	29.35	100	31.66	100	40.35	100	40.45	100

^a Resins are liquid weight at stated solids of UF 65%, MUF 60%, PF 47%, and PRF 60%.

^b Energy based on their higher heating value of Table 6, coal at 26.2 MJ/kg, crude oil at 45.5 MJ/kg, wood at 20.9 MJ/kg, and uranium at 381,000 MJ/kg. UF, urea-formaldehyde; MUF, melamine-urea-formaldehyde; PF, phenol-formaldehyde; PRF, phenol-resorcinol-formaldehyde.

on the HHVs of the various fuels and feedstock. Natural gas provides 71% of the energy followed by crude oil (22%) and coal (6.1%); all other sources are minor. The total embodied energy of the other resins is as follows: MUF (31.66), PF (40.35), and PRF (40.45 MJ/kg resin). The total energies differ for two groups—urea- (UF and MUF) and phenolic- (PF and PRF) type resins—with the contribution of natural gas, crude oil, and coal about the same within each resin group. More natural gas is used for the urea resins because it is the main feedstock and fuel source, and the phenolic resins use more crude oil because it is based on both natural gas and crude oil for feedstock and fuel.

Energy equivalents by process component to resin manufacturing can be of value in assessing the major contributors and for identifying opportunities for reducing energy use. Table 12 gives the embodied energy breakdown for manufacturing the various resins from in-ground

resource to the output gate of the resin plant. Of the total energy for UF and MUF resins, the embodied energy for the urea and melamine provide about 59 – 61% and for PF and PRF resins, the phenol provides about 69 – 78% of the energy. Most of the remaining energy can be attributed to the production of methanol; all other contributors are of lesser significance. Transportation of chemical inputs to the plant represent only about 1 – 3% of the total energy. Energy to provide resin manufacturing process energy and electricity for heat and emissions control represents only 2 – 7% of the total.

SENSITIVITY ANALYSIS

A sensitivity analysis was conducted per ISO protocol that involved examining the impact of varying an input parameter such as fuel to a process and examining the magnitude of the change of an output parameter such as resource

Table 12. A breakdown of energy contributors by process component to produce resins cradle-to-gate (based on higher heating value of fuels in Tables 6 and 11).

Process component	UF resin ^a		MUF resin ^a		PF resin ^a		PRF resin ^a	
	MJ/kg resin	%	MJ/kg resin	%	MJ/kg resin	%	MJ/kg resin	%
Melamine			4.72E+00	14.9				
Urea	1.73E+01	58.9	1.46E+01	46.1				
Phenol					2.78E+01	68.8	3.15E+01	77.9
Methanol	1.10E+01	37.6	1.08E+01	34.1	9.29E+00	23.0	4.58E+00	11.3
Resorcinol								
Ethanol							3.29E-01	0.81
Formic acid 10% solids	3.45E-02	0.12	3.95E-02	0.12				
Ammonium sulfate 20% solids	1.24E-03	0.00	1.16E-03	0.00				
Sodium hydroxide 50% solids	8.22E-03	0.03	7.82E-03	0.02	2.27E+00	5.63	1.49E-01	0.37
Trailer diesel	3.25E-02	0.11	2.01E-01	0.63	6.26E-02	0.16	9.29E-01	2.30
Diesel locomotive	2.61E-01	0.89	2.21E-01	0.70	1.91E-01	0.47	2.24E-01	0.55
Natural gas	3.74E-01	1.28	6.92E-01	2.19	4.21E-01	1.04	1.64E+00	4.06
Natural gas equipment (surrogate propane)	4.80E-07	0.00	7.95E-07	0.00	1.26E-06	0.00	1.28E-06	0.00
Electricity, USA average process	1.93E-01	0.66	2.28E-01	0.72	2.40E-01	0.60	9.05E-01	2.24
Electricity, USA average emissions equipment	1.49E-01	0.51	1.55E-01	0.49	1.05E-01	0.26	1.73E-01	0.43
Total	29.35	100	31.66	100	40.35	100	40.45	100

^a Resins are liquid weight at stated solids of UF 65%, MUF 60%, PF 47%, and PRF 60%.

^b No process in life-cycle inventory database for resorcinol.

UF, urea-formaldehyde; MUF, melamine-urea-formaldehyde; PF, phenol-formaldehyde; PRF, phenol-resorcinol-formaldehyde.

use or CO₂ (fossil) emission. The sensitivity analysis first assessed the input parameters such as urea, phenol, melamine, resorcinol, methanol, fuels, electricity, and transportation on their impact of emissions to air, water, and land. A test was done to determine whether changing a specific input such as urea would result in an expected change for output emissions. The magnitude of the impact was found to be dependent on the input parameter and also on the output parameter of interest. For a complete sensitivity analysis, see Wilson (2009).

CARBON CONTENT AND FOOTPRINT OF RESINS

With respect to climate change and related issues as a result of increased greenhouse gas (GHG) emissions to the atmosphere, three topics are of interest to understanding the net impact of a material on the environment: 1) the carbon store in material that can in some instances be used to offset CO₂ emissions to and in the atmosphere; 2) the carbon footprint of a material that gives the amount of GHGs released to the atmosphere during a material's life cycle; and 3) the net carbon flux that is a sum of the carbon footprint and the carbon store

(a negative value) based on sources that have near-time renewing carbon cycles. The net carbon flux gives the net carbon or its CO₂ equivalents impact for a material on the environment in terms of global warming and climate change.

All resins in this study have significant carbon content that is based on their source of either crude oil or natural gas feedstock to make input chemicals. Because these resins have carbon contents that can be considered a carbon store, and their carbon cycle is in millions of years to regenerate and not near-term, the carbon store is not considered as an offset in the net carbon flux determination. Wood products, unlike the resins, have a carbon store in their wood component based on a near-term carbon cycle of decades; therefore, its store is included as an offset when determining the net carbon flux (Wilson 2010a, 2010b). The carbon component of wood is part of the closed carbon cycle of trees to wood to emissions and then back to trees as a result of the absorption of CO₂ during the growing of trees. The carbon store remains with the cured resin in the wood composite product until either it burns or chemically breaks down with CO₂ returning to the atmosphere. Although the carbon components of the

various resins are given here, as stated, their carbon store component is not included in the net carbon flux value because its carbon cycle is not continuously renewing in the near term.

The cured formaldehyde-based resins of this study are comprised of 25.4% carbon by weight for UF resin, MUF (27%), PF (59.5%), and PRF (57%) (Broline 2008). These are approximate values based on certain assumptions and recognizing that the carbon content varies with formulation, MR, and resin solids. To determine the carbon content, it was assumed that 100% of formaldehyde remains in the cured resin, in-mill additives are included, and a paraformaldehyde-based hardener is used for the PRF resin to manufacture glulam. Contemporary formaldehyde-based resins have very low emissions of formaldehyde; therefore, the no-emission assumption can be considered as a good first approximation until new studies are done to document their emission over time for in-service applications. It should be noted that oxazolidine-based hardeners are generally used for PRF resin in the manufacture of I-joists, which would provide slightly different carbon content.

The carbon footprint is determined by the CO₂ equivalents of all GHG emissions during the life cycle of a product, in this case from in-ground resources through extraction, delivery of resources, and manufacture of the liquid resin (cradle-to-gate). The carbon footprint is equal to the Global Warming Potential because it is also based on CO₂ equivalents of the GHG emissions. The CO₂ equivalents of each GHG can be determined by multiplying its comparative reactive factor in the atmosphere to that for carbon dioxide based on a 100-yr time horizon (IPCC 2007). There are three GHG that are of significance for the life cycle of these resins—CO₂, CH₄ (methane), and N₂O (nitrous oxide—listed as dinitrogen oxide in the tables). The carbon footprint of each resin in terms of its kg CO₂ equivalents (eq) is equal to the kg CO₂ fossil emissions plus 25 times the kg CH₄ emissions plus 298 times the kg N₂O emissions. The contribution of the other GHGs such as fluorinated gases does not occur in this study. The carbon footprint for the life cycle cradle-to-gate of each resin is given in Table 13

Table 13. *The carbon footprint to produce formaldehyde-based resins cradle-to-gate is the same as the net carbon flux because their carbon store is not included.*

Resin	Resin solids (%)	Carbon footprint ^a	
		kg CO ₂ equivalent/ kg resin	kg CO ₂ equivalent/ kg resin
		Liquid ^b	100% solids
UF	65	1.608	2.474
MUF	60	1.775	2.958
PF	47	1.322	2.788
PRF	60	1.394	2.323

^a Carbon footprint kg CO₂ equivalent = CO₂ kg + (CH₄ kg × 25) + (N₂O kg × 298).

^b Liquid resin at stated solids content.

UF, urea-formaldehyde; MUF, melamine-urea-formaldehyde; PF, phenol-formaldehyde; PRF, phenol-resorcinol-formaldehyde.

(Wilson 2009). Because the carbon store for the various resins is not considered as an offset against the carbon footprint, the net carbon flux is equal to the carbon footprint.

DISCUSSION

The data documented in this study on the manufacture of various formaldehyde-based resins form a foundation for the scientific assessment of their environmental performance. The resin data should not be considered as a standalone product; rather, it should be used when conducting LCI and life-cycle assessment (LCA) of wood composite products that use these resins as bonding agents during their manufacture. Resins are an integral component and contributor to the performance of wood composites. An LCA of the use of resins in composites can be used in a number of ways to show their favorable performance for such environmental issues as sustainability, global warming, climate change, carbon footprint, carbon storage, carbon trading and caps, carbon taxes, green purchasing, and green building. The data can be used as stated or in an LCA to compare wood composite products with various competitive materials or assemblies of various materials. Individual LCI data of these resins can be used as benchmarks for process or product improvements or for comparing performance with those of other materials but must be on an equivalent performance basis using the same system boundary, conditions, and assumptions.

CONCLUSIONS

Cradle-to-gate LCI studies were conducted of manufacturing 1.0 kg of liquid (with water) formaldehyde-based resins—the LCI functional unit for this study—in the US. The study covered data analyses from raw material resources in the ground through resins manufacturing for production year 2005. Production data were collected by survey of resin manufacturers representing about 60–75% of total US production of UF, MUF, PF, and PRF resins. Secondary LCI data from the Franklin Associates and Ecoinvent databases were used for impacts of input chemicals, fuels, electricity, and transportation.

The quality of the LCI data collected for the manufacture of these resins was high as judged by assessments for similarity of values, MR of formaldehyde (F) to urea (U), melamine (M), phenol (P), resorcinol (R), or some combination of these components and the mass flow of material in and out of the process. The MRs were found to be as expected, F:U (1.09), F:U + M (1.16), F:P (2.23), and F:P + R (0.61).

Assigning of environmental burden in the production of these resins was entirely to the product because no coproducts were produced during the process. Of the output functional unit of 1.0 kg of liquid resin at their stated solids content, the main input components were methanol to produce the formaldehyde in a reactor accompanied by the addition of catalyst and then a second reaction in another reactor of the formaldehyde with urea, melamine, phenol, and/or resorcinol to make the final desired resin product. Used throughout the process were a number of lesser significant quantities of acids and caustics.

Environmental impacts were assessed for those at the resin manufacturing site (referred to as on-site emissions) and those for cradle-to-gate, which begin with resources in the ground through extraction, generation, delivery, and resin manufacture. Most on-site impacts are small compared with the cradle-to-gate impacts. For example, to produce 1.0 kg of UF liquid resin, the on-site energy use is 0.394 MJ compared with 29.35 MJ/kg resin for cradle-to-gate; and emis-

sions to air such as CO₂, CO, VOCs, particulate, formaldehyde, and methanol are 1, 1, 100, 1, 69, and 3%, respectively, for the on-site compared with the cradle-to-gate values. Only VOCs and formaldehyde were high because the VOCs were only recorded on-site as a group and only given individually for off-site impacts and the formaldehyde was produced on-site resulting in higher emissions. The on-site emissions to water and land are likewise smaller. Overall, the resin operations are resource-efficient and relatively friendly to the environment.

The embodied energy considering all fuels and feedstock from cradle-to-gate to produce UF, MUF, PF, and PRF resins is 29.35, 31.66, 40.35, and 40.45 MJ/kg resin, respectively. In terms of their energy equivalents, the manufacture of the input primary chemicals of methanol, urea, melamine, and phenol contributed the most to the total energy. No LCI data were given for resorcinol in either of the two databases used; as such, no burdens were assigned to it. The transportation of chemical inputs to the resin plants and on-site processing fuels and electricity were all minor contributors to the total energy.

The net carbon flux is equal to the carbon footprint to manufacture the various formaldehyde resins because their carbon store is not considered as an offset. The carbon footprint provides a measure of the amount of GHGs emitted to the atmosphere in the cradle-to-gate life cycle of producing the resin from in-ground resources to the resin product gate and is used as a measure of its impact on global warming and climate change. The carbon footprint of 1.0 kg of liquid resin varied by resin type, UF (1.608), MUF (1.775), PF (1.322), and PRF (1.394 kg CO₂ equivalents). These LCI data will also be publicly available as a comprehensive report (Wilson 2009) posted on the CORRIM web site at www.corrim.org.

To benefit from the availability of a LCI database for these formaldehyde-based resins, the following additional studies are recommended: 1) extract pertinent data that documents the favorable environmental performance of the resins; and 2) edit prior CORRIM LCI studies

that used these resins to incorporate the LCI data developed in this study.

ACKNOWLEDGMENTS

This research project would not have been possible without the financial support provided by the USDA Forest Service Forest Products Laboratory (04-CA-11111137-094), CORRIM's contributing university members, and the contributions of many companies. Special appreciation is given to those people and companies providing data to this study: in particular Tom Holloway and Bruce Broline of Arclin and Mark Alness and Curtis Shelast of Hexion Specialty Chemicals as well as numerous others; this study was made possible because of their efforts and input. Recognition is also extended to the Engineered Wood Technology Association (EWTA) and its membership who also provided technical assistance as well as financial support. Any opinions, findings, conclusions, or recommendations expressed in this article are those of the author and do not necessarily reflect the views of contributing entities.

REFERENCES

- Broline B (2008) Manager, Intellectual Property, Arclin USA, Inc., Springfield, OR. Personal communication, J Wilson, 11 December 2008.
- CORRIM (2001) Research guidelines for life cycle inventories. Consortium for Research on Renewable Industrial Materials. CORRIM, Inc., Seattle, WA. 2 Apr. 47 pp.
- Ecoinvent (2008) Ecoinvent database and methodology. Data version 2.0. December. http://www.ecoinvent.org/fileadmin/documents/en/01_OverviewAndMethodology.pdf (15 May 2008).
- EIA (2007) Net generation by energy source by type of producer, 1995 through 2006. Energy Information Administration. <http://www.eia.doe.gov/cneaf/electricity/epa/epat1p1.html> (27 November 2007).
- FAL (2004) The Franklin Associates life cycle inventory database. SimaPro7 Life-Cycle Assessment Software Package version 7.1. Franklin Associates Ltd. June. <http://www.pre.nl/download/manuals/DatabaseManualFranklinUS98.pdf> (15 January 2008).
- IPCC (2007) Climate change 2007: The physical science basis. Contribution of working group I to the Fourth Assessment Report. Chapter 2: Changes in Atmospheric Constituents and in Radiative Forcing. Intergovernmental Panel on Climate Change. <http://www.ipcc.ch/pdf/assessment-report/ar4/wg1/ar4-wg1-chapter2.pdf> (12 December 2008).
- ISO (2006a) Environmental management—Life cycle assessment—Principles and framework. ISO 14040. First Edition 2006-06-31. International Organization for Standardization, Geneva, Switzerland. 32 pp.
- ISO (2006b) Environmental management—Life cycle assessment—Requirements and guidelines. ISO 14044. First Edition 2006-07-01. International Organization for Standardization, Geneva, Switzerland. 46 pp.
- Kline ED (2005) Gate-to-gate life inventory of oriented strand board. *Wood Fiber Sci 37(CORRIM Special Issue):*74 – 84.
- Marra AA (1992) Technology of wood bonding: Principle in practice. Van Nostrand Reinhold, New York, NY. 454 pp.
- Milota MR, West CD, Hartley ID (2005) Gate-to-gate life inventory of softwood lumber production. *Wood Fiber Sci 37(CORRIM Special Issue):*47 – 57.
- Pizzi A (1994) Advanced wood adhesives technology. Marcel Dekker, Inc., New York, NY. 289 pp.
- PRé Consultants (2007) SimaPro7 Life-cycle assessment software package, Version 7.10. Plotterweg 12, 3821 BB, Amersfoort, The Netherlands. <http://www.pre.nl/simapro/manuals/default.htm> (27 February 2007).
- Puettmann ME, Wilson JB (2005) Gate-to-gate life-cycle analysis of glued-laminated timbers production. *Wood Fiber Sci 37(CORRIM Special Issue):*99 – 113.
- USCB (2007) US Census Bureau 2002 NAICS definitions. <http://www.census.gov/epcd/naics02/def/ND321219.HTM> (27 November 2007).
- USDOE (2007) Net generation by energy source by type of producer. US Department of Energy. http://www.eia.doe.gov/cneaf/electricity/epa/generation_state.xls (15 January 2007).
- USEPA (2007) Source classification codes. US Environmental Protection Agency. http://www.epa.gov/ttn/chieff/codes/scc_feb2004.xls (27 November 2007).
- Wilson JB (2009) Resins: A life-cycle inventory of manufacturing resins used in the wood composites industry. Consortium for Research on Renewable Industrial Materials (CORRIM, Inc.). University of Washington, Seattle, WA. January. 105 pp.
- Wilson JB (2010a) Life-cycle inventory of particleboard in terms of resources, emissions, energy and carbon. *Wood Fiber Sci 42(CORRIM Special Issue):*90 – 106.
- Wilson JB (2010b) Life-cycle inventory of medium density fiberboard in terms of resources, emissions, energy and carbon. *Wood Fiber Sci 42(CORRIM Special Issue):* 107 – 124.
- Wilson JB, Dancer ER (2005a) Gate-to-gate life-cycle inventory of laminated veneer lumber production. *Wood Fiber Sci 37(CORRIM Special Issue):*114 – 127.
- Wilson JB, Dancer ER (2005b) Gate-to-gate life-cycle inventory of I-joist production. *Wood Fiber Sci 37(CORRIM Special Issue):*85 – 98.
- Wilson, JB, Sakimoto ET (2005) Gate-to-gate life-cycle inventory of softwood plywood production. *Wood Fiber Sci 37(CORRIM Special Issue):*58 – 73.